

Europäisches Patentamt

European Patent Office

Office européen des brevets



(11) EP 0 230 472 B2

(12) **NEW EUROPEAN PATENT SPECIFICATION**

- (45) Date of publication and mention of the opposition decision:
13.12.2000 Bulletin 2000/50
- (45) Mention of the grant of the patent:
27.01.1993 Bulletin 1993/04
- (21) Application number: 86903608.7
- (22) Date of filing: 19.06.1986
- (51) Int. Cl.⁷: G01N 27/30, G01N 27/416
- (86) International application number:
PCT/JP86/00311
- (87) International publication number:
WO 86/07632 (31.12.1986 Gazette 1986/28)

(54) **BIOSENSOR AND METHOD OF MANUFACTURING SAME**

BIOSENSOR UND DESSEN HERSTELLUNG

CAPTEUR BIOLOGIQUE ET SON PROCEDE DE FABRICATION

- (84) Designated Contracting States:
DE FR GB
- (30) Priority: 21.06.1985 JP 13642385
07.11.1985 JP 24920385
07.11.1985 JP 24920485
11.12.1985 JP 27820285
02.04.1986 JP 7572886
- (43) Date of publication of application:
05.08.1987 Bulletin 1987/32
- (73) Proprietor:
MATSUSHITA ELECTRIC INDUSTRIAL CO., LTD.
Kadoma-shi, Osaka-fu, 571 (JP)
- (72) Inventors:
• NANKAI, Shiro
Hirakata-shi Osaka-fu 573 (JP)
• KAWAGURI, Mariko
1-chome Moriguchi-shi Osaka-fu 570 (JP)
• IJIMA, Takashi
Hirakata-shi Osaka-fu 573 (JP)
- (74) Representative:
Bühling, Gerhard, Dipl.-Chem. et al
Patentanwaltsbüro
Tiedtke-Bühling-Kinne & Partner
Bavariaring 4
80336 München (DE)
- (56) References cited:
- | | |
|-----------------|------------------|
| EP-A- 0 066 648 | EP-A- 0 127 958 |
| JP-A- 6 024 444 | JP-A- 59 166 852 |
| US-A- 3 791 933 | US-A- 3 897 326 |
| US-A- 3 983 005 | US-A- 4 176 008 |
| US-A- 4 225 410 | US-A- 4 274 832 |
- Japanese published application 8385147
 - Bunseku Kagaku, 33 (9), 471-476, 1984
 - Anal.Chim Acta, 153, 175-180, 1983
 - Analytical Chemistry 55, 498-514, 1983
 - Y.K. Cho and L.B. Bailey: "Immobilization of Enzymes on Activated Carbon: Selection and Preparation of the Carbon Support". Biotechnol. Bioeng; Vol. 21, pp. 461-476 (1979)
 - O.Miyawaki and L.B. Wingard, Jr.: "Electrochemical and Enzymatic Activity of Flavin Adenine Dinucleotide and Glucose Oxidase Immobilized by Adsorption on Carbon". Biotechnol. Bioeng; Vol. 26, pp 1364-1371(1984)
 - H.J. Wieck, C. Shea, nd A.M. Yacynych: "Reticulated Vitreous Carbon Electrode Materials Chemically Modified With Immobilized Enzyme". Anal. Chim. Acta; Vol. 142, pp 277-279 (1982)
 - H.S. Borovetz, et al.: "Protein Adsorption in Vitro Onto Biomaterial Surfaces Covered with Ulti Carbon". Biomater., Med. Dev., Artif. Organs, Vol. 10, pp 187-203 (1982)
 - M.L. Rudea and T.M. Price: "The Initial Stages of Adsorption of Plasma Derived Proteins on Artificial Surfaces in a Controlled Flow Environment". J. Biomed. Mater. Res., Vol. 19, pp. 57-66 (1985)
 - S.G. Riccitelli, F.H. Bilge and R.C. Eberhart: "Adsorbed Protein Visualization on LTI Carbon". Trans. Am. Soc. Artif. Intern. Organs, Vol. 30, pp 420-426 (1984)

EP 0 230 472 B2

Description

[0001] This invention relates to a biosensor according to the preamble of Claim 1 and also to a method for producing the same.

[0002] In recent years, a variety of biosensors have been developed using specific catalytic actions of enzymes, and their applications to the clinical and examining field have been attempted. As inspection items and specimens are now increasing, there is a demand for biosensors which permit rapid and accurate measurements.

[0003] With a sensor for glucose, for instance, since diabetics are drastically increasing in number, the measurement and control of blood-sugar levels by hitherto employed procedures in which the blood is centrifugated to obtain plasma and subjected to the measurement, takes a relatively long time. Thus, a sensor of the type which enables one to measure it with the whole blood is now required. In the simplest form, there is known a sensor which includes, similar to a urine test paper, a support and a carrier formed on the support and containing an enzyme reacting only with glucose and a dye which undergoes a change at the time of the enzyme reaction or with a product formed during the enzyme reaction. The blood is added to the carrier, and a change of the dye after a certain period of time is measured visually or optically. However, this system is disadvantageous in that colored matters in the blood greatly interfere with the measurement, resulting in a low accuracy.

[0004] A biosensor of the type corresponding to the preamble of claim 1 (shown in Fig. 1) has been described in EP-A-0 136 362 as a system in which a specific component in a biological sample is quantitatively determined in high accuracy. This biosensor includes an insulating substrate 7, a measuring electrode 8 and a counter electrode 9 primarily made of platinum, which have, respectively, leads 10, 11, embedded in the substrate 7, and a perforated body 12 which covers exposed portions of these electrodes and carries an oxido-reductase and an electron acceptor. When the liquid sample is dropped on the perforated body, whereupon the oxido-reductase and the electron acceptor in the perforated body dissolve in the sample liquid, thus permitting the enzyme reaction with a substrate in the liquid sample to proceed. As a result, the electron acceptor is reduced. After completion of the enzyme reaction, the reduced electron acceptor is electrochemically oxidized and a concentration of the substrate in the liquid sample is determined from a current for the oxidation.

[0005] In this arrangement, although the measurement can be performed simply by replacing the perforated body every measurement, additional procedures, such as washing, are undesirable for the electrode system. If parts including the electrodes could be disposable replaced whenever the measurement is effected, the

measuring procedure would become very simple but the system would be very expensive in view of the electrode materials such as platinum and the arrangement. Although the platinum electrodes may be formed by a sputtering method or a vacuum evaporation method, they are still expensive in view of the manufacture.

[0006] The reference J. Agric. Biol. Chem. volume 49 (2), 541 - 543 (1985) describes the use of a glucose oxidase-immobilized carbon paste electrode as a glucose sensor. According to this reference the enzyme is immobilized on the surface of a carbon paste electrode by coating the surface of the electrode with a nitrocellulose film.

[0007] It is therefore the object of the present invention to provide a biosensor which measures a specific component in a biological sample simply, rapidly and in high accuracy and, furthermore, can be handled easily and manufactured simply.

[0008] According to the invention this object is achieved by providing a biosensor according to the preamble of claim 1 with an electrode system made primarily of carbon and covering the surface of at least the measuring electrode with albumin or glucose oxidase by adsorption.

[0009] The invention is advantageously developed by the measures mentioned in the subclaims.

[0010] Fig. 1 is a schematic view of a known sensor for glucose using an enzyme electrode; Fig. 2 is a schematic view of a biosensor according to one embodiment of the invention; Fig. 3 is a longitudinal section of the biosensor shown in Fig. 2; Figs. 4, 5, and 6 are, respectively, response characteristics of the biosensor shown in Fig. 2; Fig. 7 is a schematic view of a biosensor according to another embodiment of the invention; and Fig. 8 is a longitudinal section of the biosensor shown in Fig. 7.

Example 1

[0011] A sensor for glucose is described as one embodiment of a biosensor. Fig. 2 shows one embodiment of a sensor for glucose and is an exploded view for constituent parts. A conductive carbon paste containing a resin binder is printed, by screen printing, on an insulative base 12 made of polyethylene terephthalate in the form of parallel stripes, followed by heating for drying to form an electrode system consisting of a counter electrode 13, a measuring electrode 14 and a reference electrode 15. The electrode system is partially covered, after which an insulative paste mainly composed of a polyester is printed in the same manner as described above while leaving portions 13', 14' and 15' (each 1 mm² in area) of the respective electrodes acting as electrochemical sites, followed by heating to form an insulative layer 16. Subsequently, the exposed portions 13', 14' and 15' are polished and subjected to heat treatment in air at 100°C for 4 hours.

[0012] Thereafter, a punched holding frame 17 of a

synthetic resin such as a polyester is adhered to the insulative layer 16. A perforated body 18 having an enzyme and an electron acceptor is placed in the hole of the frame 17 so that the electrodes 13', 14' and 15' are completely covered. A resin cover 19 having an opening which is smaller than the outer diameter of the perforated body 18 is adhered, thereby obtaining an integrally assembled sensor. The sectional view of this biosensor taken along the measuring electrode 14 is shown in Fig. 3. The perforated body used above is fabricated as follows: a nylon non-woven fabric is provided as a base; the base is dipped in a solution of 200 mg of glucose oxidase as an oxydo-reductase and 400 mg of potassium ferricyanide as an electron acceptor dissolved in 1 ml of a phosphate buffer solution containing 0.25 wt% of a surface active agent (polyethylene glycol alkylphenyl ether) and having a pH of 5.6 and immersed in ethanol containing 0.25 wt% of a surface active agent for crystallization; and the thus immersed base is dried under reduced pressure to obtain a perforated material.

[0013] A glucose standard solution provided as a liquid sample was dropped in the perforated body of the thus fabricated sensor. Two minutes after the dropping, a pulse voltage of 700 mV based on the reference electrode was applied, by which the measuring electrode was polarized anodically.

[0014] In this case, the added glucose reacts with potassium ferricyanide by the action of the glucose oxidase contained in the perforated body 18 to form potassium ferrocyanide. Upon the application of the pulse voltage for the anodic polarization, a current for the oxidation in proportion to a concentration of the formed potassium ferrocyanide is obtained. This current value corresponds to a concentration of the glucose substrate.

[0015] Fig. 4 shows the relation between a current obtained 10 seconds after application of the voltage and a glucose concentration as one of response characteristics of the sensor, revealing a very good linearity.

Example 2

[0016] The procedure for fabricating the sensor for glucose as described in Example 1 was repeated except that the thermal treatment after polishing of the carbon electrodes was effected at 100°C, 70°C, 60°C and 50°C, and that the heat treatment was not effected, thereby fabricating a plurality of sensors for each case. These sensors were kept at 30°C and their variation in response to the glucose standard solution was determined. Fig. 5 shows a variation of a response current relative to an initial response current taken as 100% for the sensors using the electrodes thermally treated at different temperatures. As will be clearly seen from the figure, the variation of the response accompanied by the storage is not so great when the treating temperature is 60°C or higher. However, such a variation is great for 50°C and also for the non-treatment. This is consid-

ered to result from the fact that the exposed surface portion of the polished carbon printed electrodes is not stabilized. When the electrode surface was not polished, a response current was about 1/3 of that of polished electrodes. The difference in response current between the polished and non-polished electrodes is considered to be attributed to partial covering of the carbon surface with a resin component contained as a binder in the paste. Polishing can remove the resin binder from the carbon electrode surface and can uniformly smooth the electrode surface. In addition, the heat treatment at temperatures not lower than 60°C, preferably 60 - 170°C, for 1 - 8 hours permits the the exposed electrode portion to become stabilized.

[0017] According to our experiments, when the heat treatment was effected at a temperature of 70 - 150°C for 4 hours, good results were obtained in that the variation in response current after storage was very small.

[0018] Good results cannot be obtained when the heat treatment is effected at temperatures not higher than 50°C as discussed above. On the contrary, the heat treatment at temperatures higher than 170°C should rather be avoided because the polyethylene terephthalate substrate of the sensor tends to undergo thermal deterioration and the resin binder in the carbon paste is apt to deteriorate.

Example 3

[0019] Similar to the procedure described in Example 1, electrodes were formed on an insulative base and, after polishing, were thermally treated at 100°C for 4 hours. Thereafter, an aqueous solution of albumin (50 mg/ml) was dropped over the surface of the electrode portions 13', 14' and 15' and allowed to stand for 5 - 10 minutes, followed by washing with water to remove an excess of the albumin and drying. By the above procedure, the albumin was adsorbed on the respective electrode surfaces.

[0020] After formation of the electrode system partially covered with the albumin, sensors for glucose were made in the same manner as in Example 1.

[0021] A serum sample containing about 90 mg/dl of glucose was dropped in position of the 10 glucose sensors fabricated above. After 2 minutes, a pulse voltage of 700 mV was applied for measurement in the same manner as in Example 1. Good reproducibility was attained as shown in A in Fig. 6. On the other hand, glucose sensors were fabricated in the same manner as described above but using electrodes not subjected to adsorption with albumin. These sensors were subjected to measurement in the same manner as set forth above. As shown in B in Fig. 6, the variation of the response current is greater than that of A. A and B are both indicative of the response current for 10 glucose sensors fabricated in the same manner, but the difference in reproducibility depending on the adsorption treatment is considered to ascribe to the difference in adsorbability

of adsorbates, such as proteins, in the serum sample on the electrodes. As is seen from A, the electrodes adsorbing sufficiently with albumin can prevent the response current from scattering.

[0022] Instead of albumin, an aqueous solution of glucose oxidase (100 mg/ml) was used for the treatment in the same manner as described above, with the result that the response characteristic of a high reproducibility was obtained.

[0023] If at least measuring electrode among the electrodes is subjected to the adsorption treatment, similar results are obtained.

Example 4

[0024] In the same manner as in Example 3, an albumin-coated electrode system was formed on an insulative base. Fig. 7 shows an exploded view of a sensor prior to assembling. A liquid-retaining layer 23 made of a perforated rayon non-woven fabric is placed, while controlling the height by means of two resin plates 22 serving as a spacer, in order to cover an electrode system therewith. Then, a filtration layer 21 made of a polycarbonate film and having a pore size of 1 μ m is mounted on the layer 23 and fixed with a holding frame 17. An enzyme and electron acceptor-bearing perforated body 18 and a sample addition layer 20 made of a cellulose non-woven fabric, both in the form of a disk, are placed in the hole of the holding frame 17. A resin cover having an opening which has a diameter smaller than the outer diameters of the perforated disk body 18 and the sample addition layer is adhered, thereby obtaining an integral combination. A sectional view of the thus integrally combined biosensor taken along the measuring electrode 1 is shown in Fig. 8.

[0025] In the same manner as in Example 1, glucose oxidase and potassium ferricyanide were incorporated in the perforated disk body 18. Glucose sensors using this perforated body 18 were fabricated. The blood (whole blood) was added to each sensor, whereupon it was rapidly spread over and through the entire surface of the sample addition layer 20. While the enzyme and potassium ferricyanide in the perforated body 18 were being dissolved in and permitted to react with the blood, red cells were filtered by means of the filtration layer 21. The resultant filtrate alone was absorbed in the liquid retaining layer 23, allowing a reaction solution to be collected on the electrode portions 13', 14' and 15' in an amount enough to cause the electrode reaction to proceed. In this manner, the glucose in the blood reacted in the same manner as in Example 1 and a concentration of the glucose could be detected through the electrode system.

[0026] It will be noted that the technique of integral assembling of a biosensor of the invention is not limited to those shown in the examples with respect to the shape and combination of the frame, the cover and the like.

[0027] The types of materials for the liquid-retaining layer, the sample addition layer and the filtration layer are not limited to those shown in the examples, but any materials which meet the purposes of the invention may be used.

[0028] On the other hand, reference has been made to, in the above examples, the three-electrode system, but the measurement would be possible using a two-electrode system consisting of a counter electrode and a measuring electrode.

[0029] As for the electron acceptor incorporated in the perforated body 18, the potassium ferricyanide used in the examples is convenient because the reaction proceeds stably. On the other hand, p-benzoquinone is suitable for high-speed measurement because of the high reaction rate. Alternatively, 2,6-dichlorophenol indophenol, methylene blue, phenazine methosulfate, potassium beta-naphthoquinone-4-sulfonate and the like may also be used.

[0030] The sensors described in the examples may be applied not only to glucose, but also to systems relating to oxydo-reductases, for example, as an alcohol sensor, a cholesterol sensor or the like. Glucose oxidase has been used as an oxydo-reductase, but other enzymes such as, for example, alcohol oxidase, xanthine oxidase, cholesterol oxidase and the like may also be used.

[0031] The biosensor of the invention can be used to measure a specific component in various biological liquid samples rapidly, accurately and simply and has very high utility in clinical examinations.

LIST OF REFERENCE NUMERALS IN THE DRAWINGS:

- [0032]**
- 1 support
 - 2 reagent layer

Claims

1. A biosensor of the type which comprises an insulative base (12) having an electrode system which includes at least a measuring electrode (14, 14') and a counter electrode (13, 13') and which is covered with a perforated body (18) having an oxidoreductase and an electron acceptor in dried state which are soluble in a liquid sample, said perforated body (18) being integrally combined with said electrode system and said base (12), wherein said biosensor electrochemically detects a variation in concentration of a substance occurring during reactions between the oxidoreductase, the electron acceptor and the liquid sample to measure a concentration of a substrate in said liquid sample, characterized in that

said electrode system is made primarily of carbon and the surface of at least said measuring electrode is covered with albumin or glucose oxidase by adsorption.

2. A biosensor according to claim 1, wherein said electrode system is covered by a liquid retaining layer (23), said perforated body (18) and a sample addition layer (20) superposed in this order.
3. A biosensor according to Claim 2, wherein a filtration layer (21) is provided on the liquid-retaining layer (23) covering said electrode system.
4. A biosensor according to Claim 2, wherein the electrode system mounted on said insulative base is covered with the liquid-retaining layer (23) whose height is regulated with two resin plates (22); a filtration layer (21), said perforated body (18) and said sample addition layer (20) which are held by a resin holding frame (17) are placed on the liquid-retaining layer (23), and said holding frame (17) is fixed to said base; and a resin cover (19) is provided on the upper surface of said holding frame (17) and has an opening whose diameter is smaller than the outer diameters of said perforated body (18) and said sample addition layer (20).
5. A method for producing a biosensor according to claim 1, said method comprising:
 - providing an insulative base,
 - printing or applying a carbon paste on said base to form an electrode system including at least a measuring electrode and a counter electrode,
 - polishing the surface of the respective electrodes,
 - subjecting the polished electrodes to a thermal treatment at a temperature of 60°C to 170°C for 1 to 8 hours,
 - covering the electrode system partially with albumin or glucose oxidase by adsorption,
 - covering the electrode system with a perforated body having an enzyme and an electron acceptor in dried state therein and
 - integrally combining said perforated body with said electrode system and said insulative base.
6. A method for producing a biosensor according to Claim 5, wherein the thermal treatment is effected at a temperature of 70 to 150° C for 4 hours.

Patentansprüche

1. Biosensor, umfassend:

eine isolierende Basis (12) mit einem Elektrodensystem, das wenigstens eine Messelektrode (14, 14') und eine Gegenelektrode (13, 13') umfasst und das mit einem perforierten Körper (18) bedeckt ist, der eine Oxidoreductase und einen Elektronenakzeptor, welche in einer flüssigen Probe löslich sind, in getrocknetem Zustand aufweist, wobei der perforierte Körper (18) mit dem Elektrodensystem und der Basis (12) integriert zusammengefügt ist und wobei der Biosensor elektrochemisch eine während den Reaktionen zwischen der Oxidoreductase, dem Elektronenakzeptor und der flüssigen Probe erfolgenden Konzentrationsänderung einer Substanz ermittelt, um die Konzentration eines Substrats in der genannten flüssigen Probe zu messen,
dadurch gekennzeichnet, dass
 das Elektrodensystem hauptsächlich aus Kohlenstoff besteht und die Oberfläche von wenigstens der Messelektrode mit Albumin oder Glucoseoxidase durch Adsorption bedeckt ist.

2. Biosensor nach Anspruch 1, wobei das Elektrodensystem mit einer Flüssigkeitsrückhalteschicht (23), dem perforierten Körper (18) und einer Probenhinzufügeschicht (20), in dieser Reihenfolge übereinandergeschichtet, bedeckt ist.
3. Biosensor nach Anspruch 2, wobei sich eine Filterschicht (21) auf der das Elektrodensystem bedeckenden Flüssigkeitsrückhalteschicht (23) befindet.
4. Biosensor nach Anspruch 2, wobei das auf der isolierenden Basis angebrachte Elektrodensystem mit der Flüssigkeitsrückhalteschicht (23), deren Höhe mittels zweier Harzplatten (22) eingestellt wird, bedeckt ist und eine Filterschicht (21), der perforierte Körper (18) und die Probenhinzufügeschicht (20), die mittels eines Halterahmens aus Harz (17) gehalten werden, auf die Flüssigkeitsrückhalteschicht (23) gelegt werden und der Halterahmen (17) an der Basis fixiert wird sowie sich auf der oberen Oberfläche des Halterahmens (17) eine Harzabdeckung (19) befindet, die eine Öffnung aufweist, deren Durchmesser kleiner ist als die äußeren Durchmesser des perforierten Körpers (18) und der Probenhinzufügeschicht (20).
5. Verfahren zur Herstellung eines Biosensors nach Anspruch 1, wobei das Verfahren umfasst:
 - Bereitstellen einer isolierenden Basis,

- Aufdrucken oder Anbringen einer Kohlenstoffpaste auf der Basis, um das Elektrodensystem mit wenigstens einer Messelektrode und einer Gegenelektrode zu bilden,
 - Polieren der Oberfläche der entsprechenden Elektroden, 5
 - thermisches Behandeln der polierten Elektroden bei einer Temperatur von 60 bis 170 °C für eine Dauer von 1 bis 8 Stunden,
 - teilweises Abdecken des Elektrodensystems mit Albumin oder Glucoseoxidase durch Adsorption, 10
 - Bedecken des Elektrodensystems mit einem perforierten Körper, der ein Enzym und einen Elektronenakzeptor in getrocknetem Zustand darin aufweist, sowie 15
 - integriertes Zusammenfügen des perforierten Körpers mit dem Elektrodensystem und der isolierenden Basis. 20
6. Verfahren zur Herstellung eines Biosensors gemäß Anspruch 5, wobei die thermische Behandlung bei einer Temperatur von 70 bis 150 °C für eine Dauer von 4 Stunden durchgeführt wird.

Revendications

1. Un biocapteur qui comporte :

une base isolante (12) comportant un dispositif d'électrodes qui inclut au moins une électrode de mesure (14, 14') et une électrode de comptage (13, 13') et qui est recouvert d'un corps perforé (18) comportant une oxydoréductase et un accepteur d'électrons à l'état sec qui sont solubles dans un échantillon liquide, ledit corps perforé (18) étant fait d'un seul bloc avec ledit dispositif d'électrodes et ladite base (12), dans lequel ledit biocapteur détecte électrochimiquement une variation de concentration d'une substance se produisant lors de réactions entre l'oxydoréductase, l'accepteur d'électrons et l'échantillon liquide pour mesurer la concentration d'un substrat dans ledit échantillon liquide, 30

caractérisé en ce que ledit dispositif d'électrodes est fait principalement de carbone, et la surface d'au moins ladite électrode de mesure est recouverte d'albumine ou de glucose-oxydase par adsorption. 50

2. Un biocapteur selon la revendication 1, dans lequel ledit dispositif d'électrodes est recouvert d'une couche (23) retenant le liquide, dudit corps perforé (18) et d'une couche (20) d'addition d'échantillon, superposés dans cet ordre. 55

3. Un biocapteur selon la revendication 2, dans lequel une couche de filtration (21) est placée sur la couche (23) retenant le liquide qui recouvre ledit dispositif d'électrodes.

4. Un biocapteur selon la revendication 2, dans lequel le dispositif d'électrodes monté sur ladite base isolante est couvert par la couche (23) retenant le liquide dont la hauteur est réglée par deux plaques de résine (22); une couche de filtration (21), ledit corps perforé (18) et ladite couche d'addition d'échantillon (20) qui sont maintenus par un châssis (17) de maintien en résine sont placés sur la couche retenant le liquide (23), et ledit châssis (17) de maintien est fixé à ladite base; et un couvercle en résine (19) est placé sur la surface supérieure dudit châssis (17) de maintien et comporte une ouverture dont le diamètre est plus petit que les diamètres extérieurs dudit corps perforé (18) et de ladite couche d'addition d'échantillon (20).

5. Un procédé pour produire un biocapteur suivant la revendication 1, ledit procédé consistant à :

- produire une base isolante,
- imprimer ou appliquer une pâte de carbone sur ladite base pour former un dispositif d'électrodes comportant au moins une électrode de mesure et une électrode de comptage,
- polir la surface des électrodes respectives,
- soumettre les électrodes polies à un traitement thermique à une température de 60 °C à 170 °C pendant 1 à 8 heures,
- couvrir partiellement le dispositif d'électrodes avec de l'albumine ou de la glucose-oxydase par adsorption,
- couvrir le dispositif d'électrodes avec un corps perforé comportant une enzyme et un accepteur d'électrons à l'état sec, et
- combiner en un seul bloc ledit corps perforé avec ledit dispositif d'électrodes et ladite base isolante. 25

6. Un procédé pour produire un biocapteur suivant la revendication 5, dans lequel le traitement thermique est effectué à une température de 70 à 150 °C pendant 4 heures. 45

FIG. 1

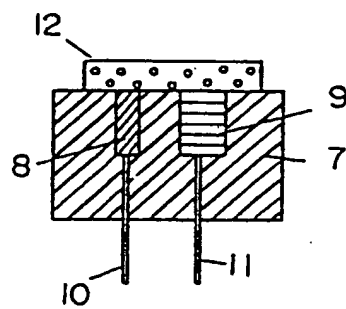

FIG. 2

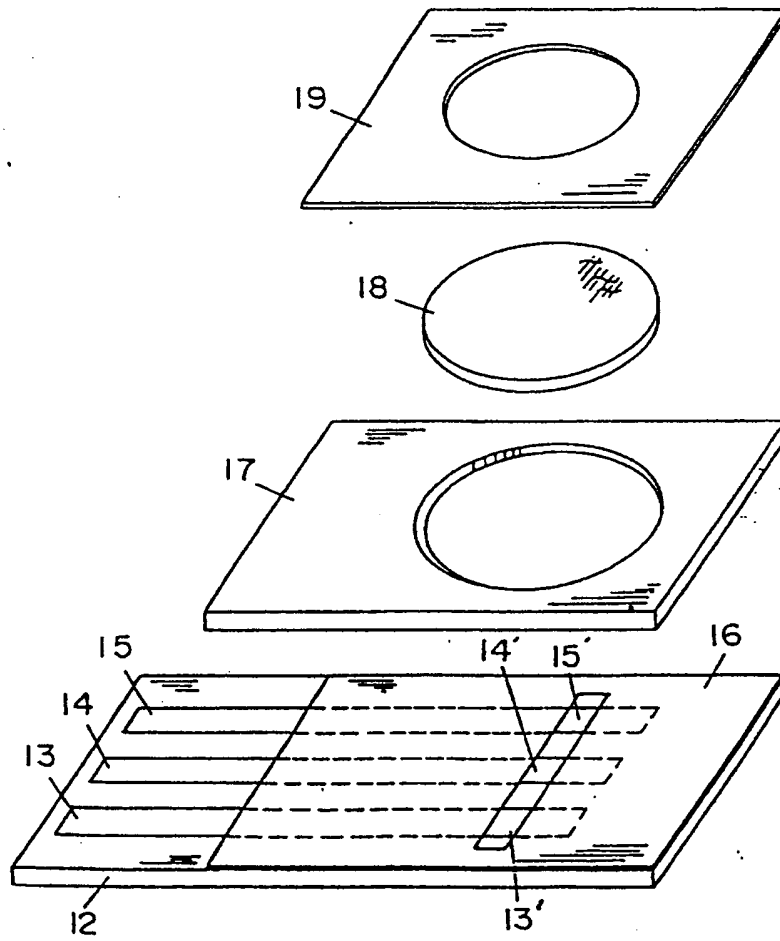

FIG. 3

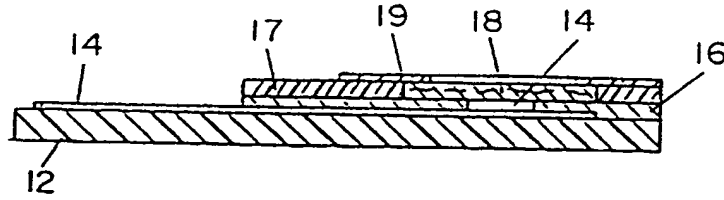
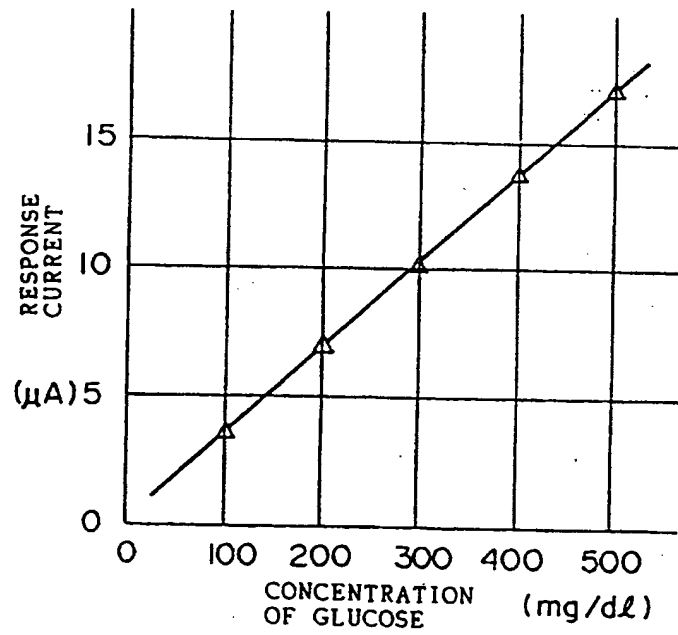

FIG. 4



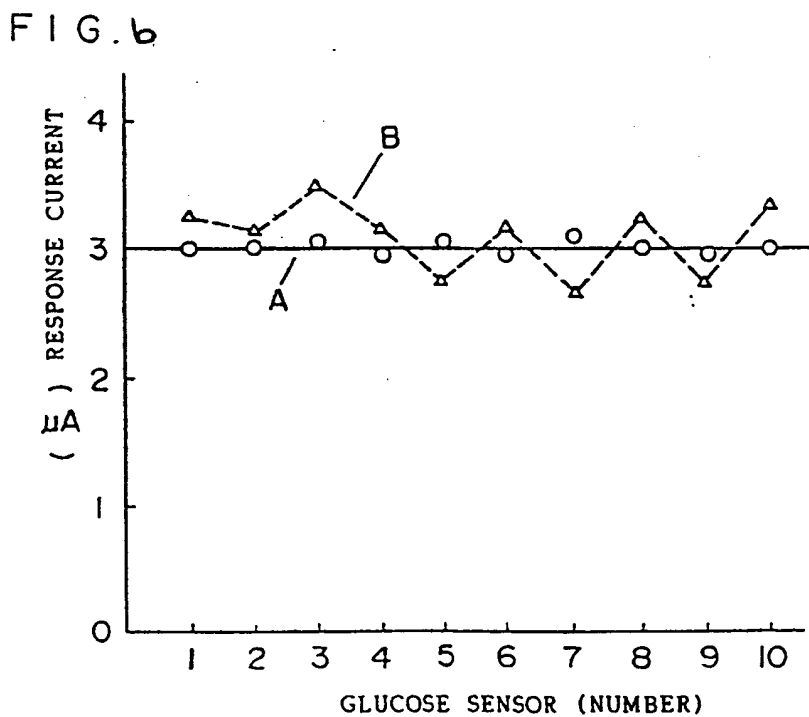
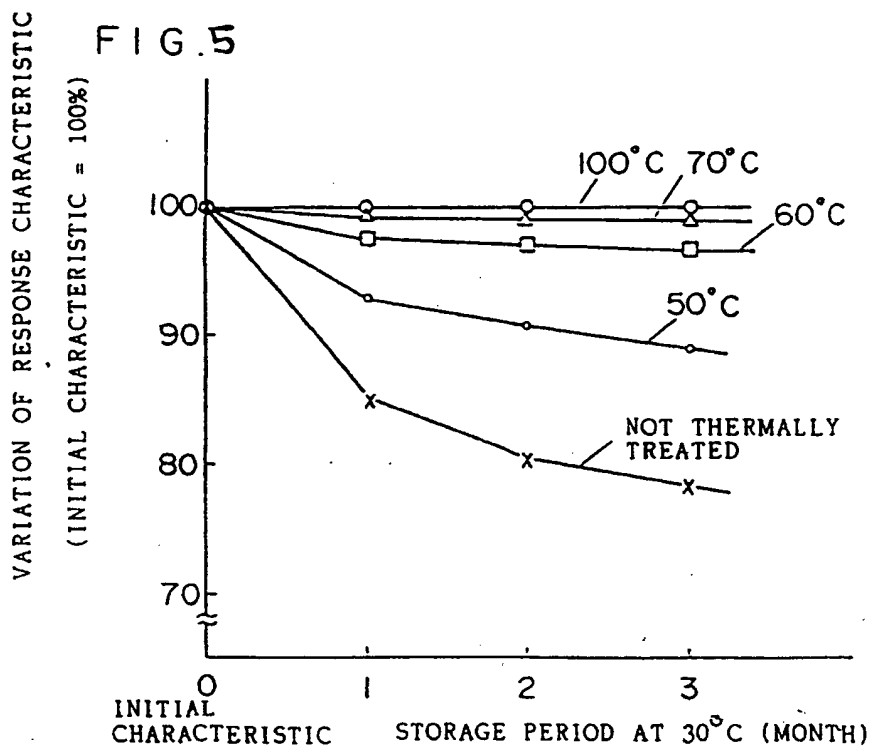

FIG. 7

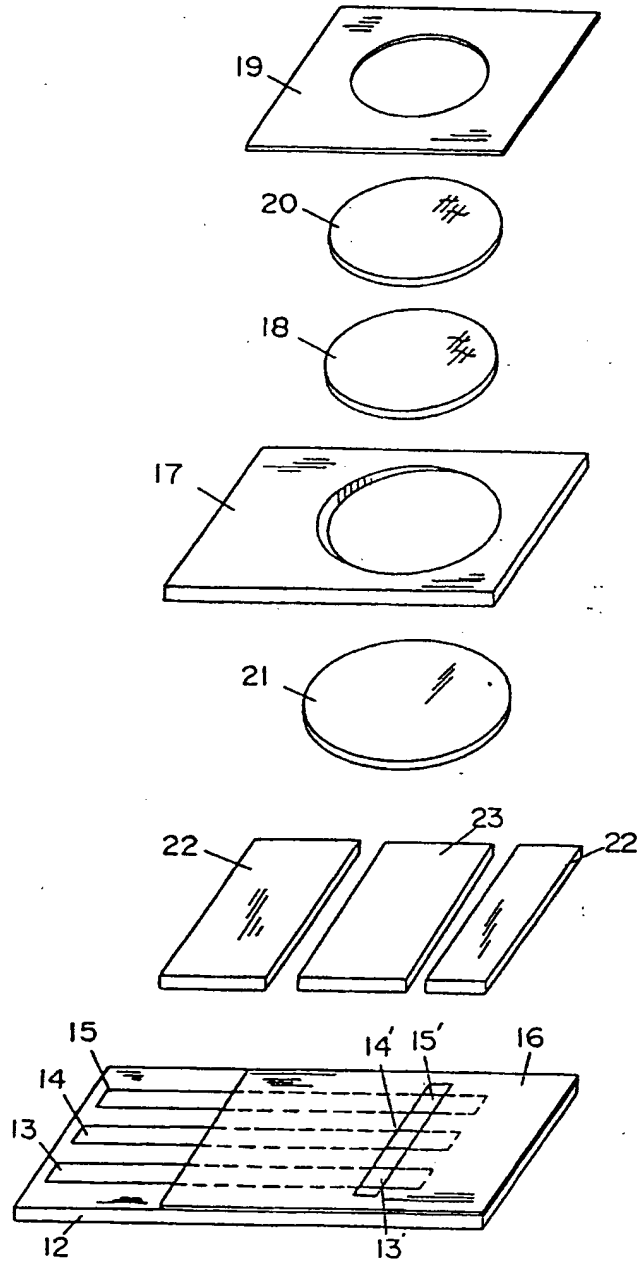

FIG. 8

